

KNOCK SENSOR

In case the fuel grade is insufficient or the octane rate is low, the abnormal burning is occur in the combustion chamber and cause severe engine damage.

The knock sensor is installed behind the No. 3 cylinder onto the cylinder block and is protected the engine from the abnormal burning knocks.

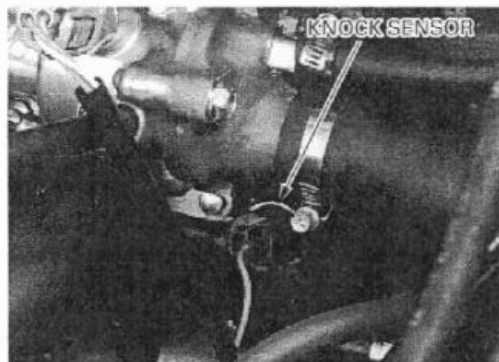

The knock sensor is pick up the engine knocks by the built-in vibration plate, and converted into voltage signal by the piezo electric element, then sent to the ECM.

The ECM is separate the received signal into the noise voltage and abnormal burning knock voltage.

If the abnormal burning voltage is excessively measured than the programmed standard value, the ECM is retard the ignition timing.

If the abnormal burning voltage is less than standard, the ECM is gradually advance the ignition timing until the standard value.

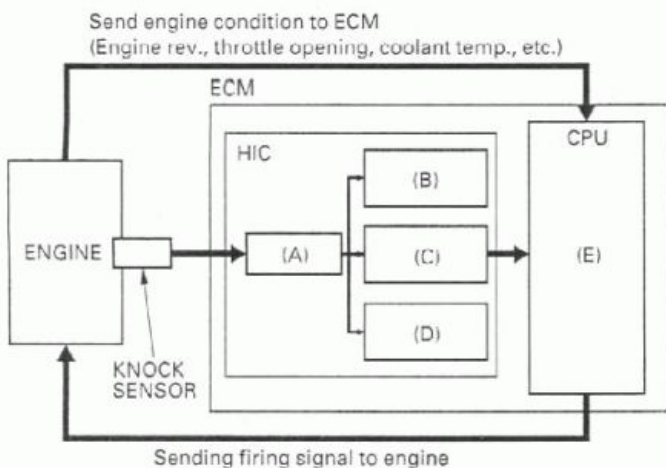

- A: Regulate the input voltage signal wave
- B: Noise voltage pick-up circuit
- C: Knock voltage pick-up circuit
- D: Sensor fail safe pick-up circuit
- E: 1. Detect the knock
2. Calculate proper ignition timing
3. Detect the fail safe

