

CYLINDER HEAD/VALVES

Remove the cam chain tensioner lifter sealing bolt and sealing washer.

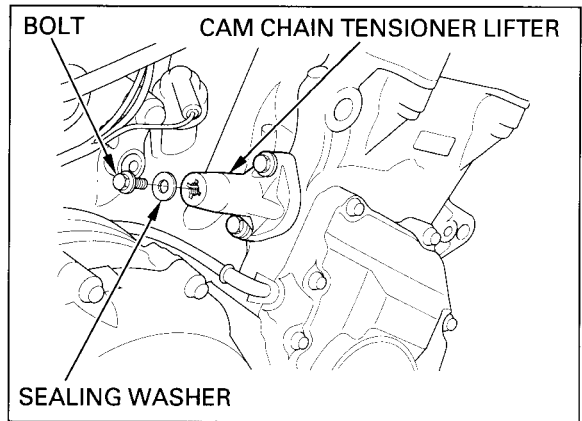

Turn the tensioner lifter shaft fully in (clockwise) and secure it using the stopper tool. This tool can easily be made from a thin (1 mm thickness) piece of steel.

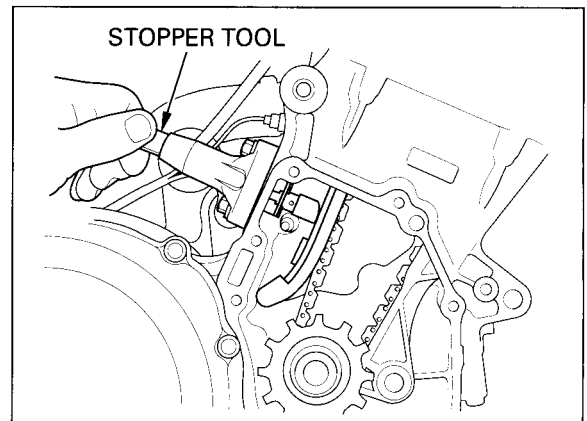
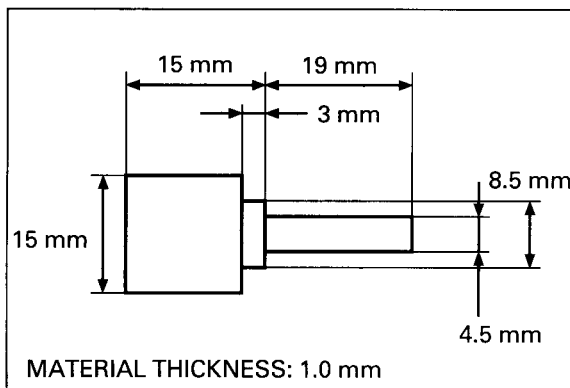

If you plan to replace the camshaft and/or cam sprocket, loosen the cam sprocket bolts as follows:

NOTE:

It is not necessary to remove the cam sprocket from the camshaft except when replacing the camshaft and/or cam sprocket.

— Remove the cam sprocket bolt from intake and exhaust camshafts.

NOTE:

Be careful not to drop the cam sprocket bolts into the crankcase.

— Turn the crankshaft one full turn (360°), remove the other cam sprocket bolt from the camshafts.

