

Attach the special tools into the left pivot needle bearing cage as shown.  
 Press the left pivot needle bearing cage out of the swingarm pivot, using the special tools and a hydraulic press.

**TOOLS:**

- Driver** 070GD-0010100 or 070GD-001A100 (U.S.A. only)
- Attachment, 34 mm** 07ZMD-MBW0100 or 07ZMD-MBWA100 (U.S.A. only)
- Ball race remover** 07948-4630100

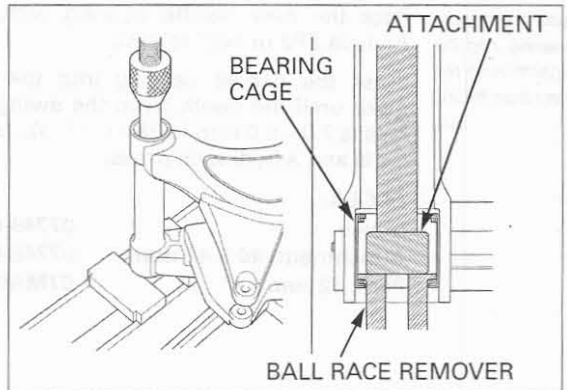

Pack the new ball bearing cavities with grease (Shell Alvania EP2 or equivalent).  
 Press the ball bearing into the swingarm right pivot until it is fully seated, using the special tools and a hydraulic press.

**TOOLS:**

- Driver** 07749-0010000
- Attachment, 40 x 42 mm** 07746-0010900
- Pilot, 25 mm** 07746-0040600

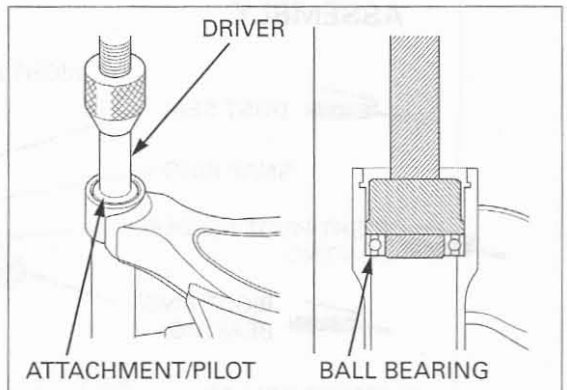

Pack the new needle bearing with grease (Shell Alvania EP2 or equivalent).  
 Press the needle bearing into the swingarm right pivot until it is fully seated onto the ball bearing, using the special tools, removed right pivot collar and a hydraulic press.

**TOOLS:**

- Driver** 07749-0010000
- Attachment, 42 mm** 07QAD-P0A0100

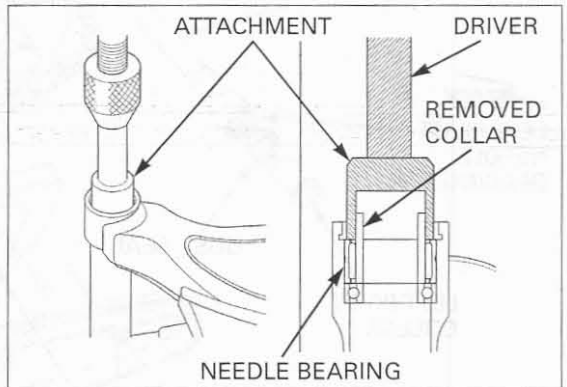

Install the snap ring into the right swingarm pivot groove securely.

