

Tap the valve stems gently with two plastic hammers as shown to seat the cotters firmly.

CAUTION:

Support the cylinder head above the work bench surface to prevent possible valve damage.

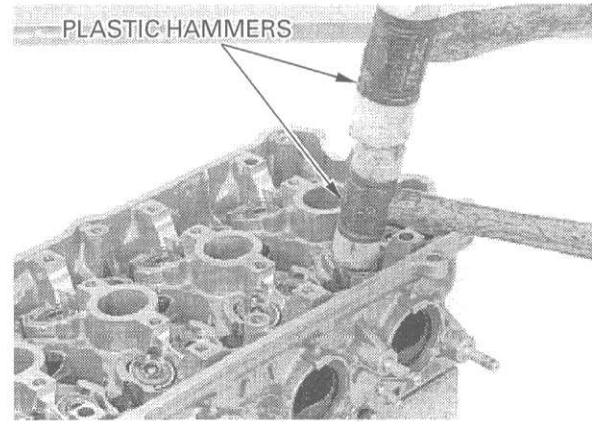

Install the insulators aligning their grooves with the bosses on the cylinder head.

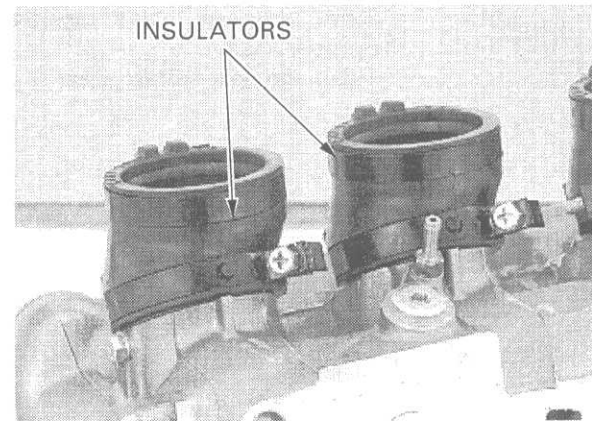

CYLINDER HEAD INSTALLATION

Install the dowel pins and a new cylinder head gasket as shown.

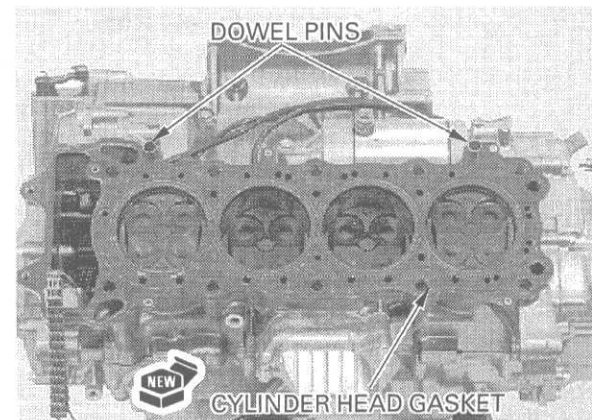

Install the cylinder head.

Apply oil to the threads and seating surface of the 9 mm special bolts/washers and install them. Tighten the 9 mm socket bolts in a crisscross pattern in 2–3 steps to the specified torque.

TORQUE: 47 N·m (4.8 kgf·m , 35 lbf·ft)

