

If the contact area is too low on the valve, the seat must be raised using a 60-degree inner cutter.

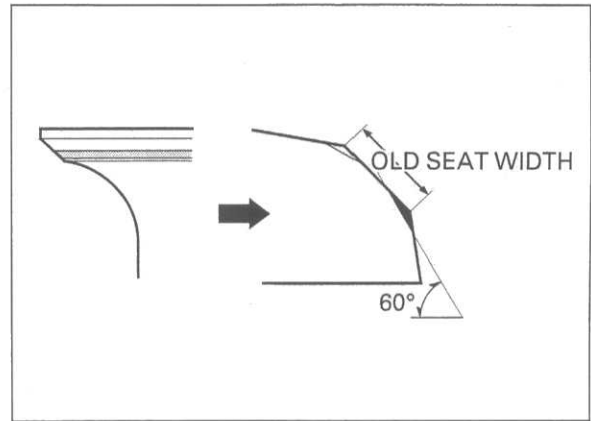

Refinish the seat to specifications, using a 45-degree finish cutter. After cutting the seat, apply lapping compound to the valve face, and lap the valve using light pressure.

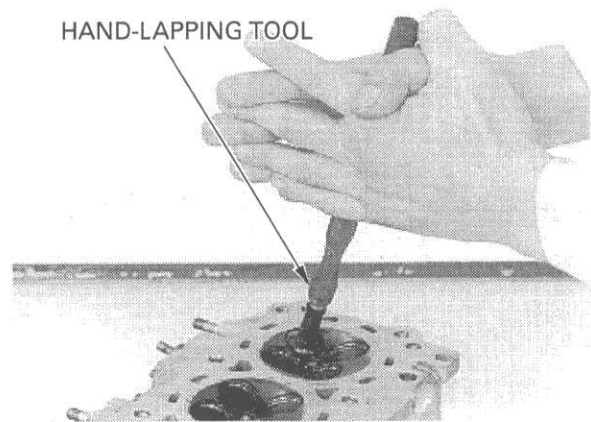

After lapping, wash all residual compound off the cylinder head and valve.

Do not allow lapping compound to enter the guides.

CYLINDER HEAD ASSEMBLY

