

INSPECTION

CAMSHAFT HOLDER

Inspect the bearing surface of the camshaft holder for scoring, scratches, or evidence of insufficient lubrication.

Inspect the oil orifices of the holders for clogging.

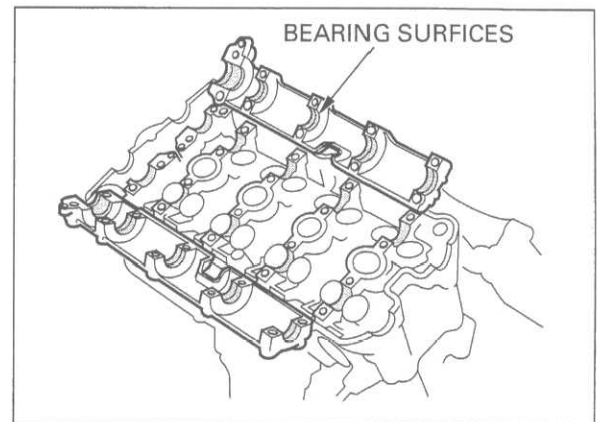

CAMSHAFT RUNOUT

Support both ends of the camshaft with V-blocks and check the camshaft runout with a dial gauge.

SERVICE LIMIT: 0.05 mm (0.002 in)

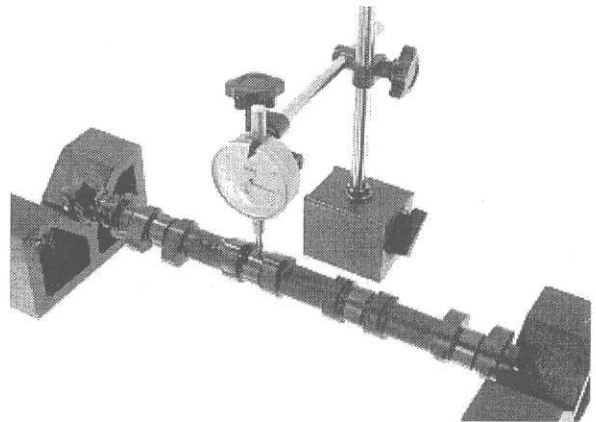

CAM LOBE HEIGHT

Using a micrometer, measure each cam lobe height.

SERVICE LIMITS:

IN: 36.11 mm (1.422 in)

EX: 35.27 mm (1.389 in)

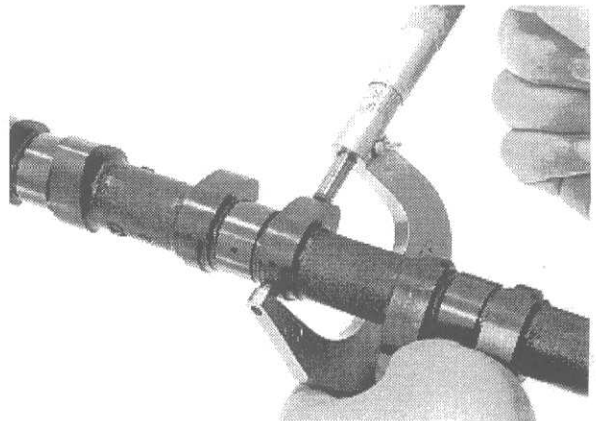

CAMSHAFT OIL CLEARANCE

Wipe any oil from the journals of the camshaft, cylinder head and camshaft holders.

Lay a strip of plastigauge lengthwise on top of each camshaft journal.

