

**K 6**

**F-29**

Tool

Outils

Werkzeug

Herramientas

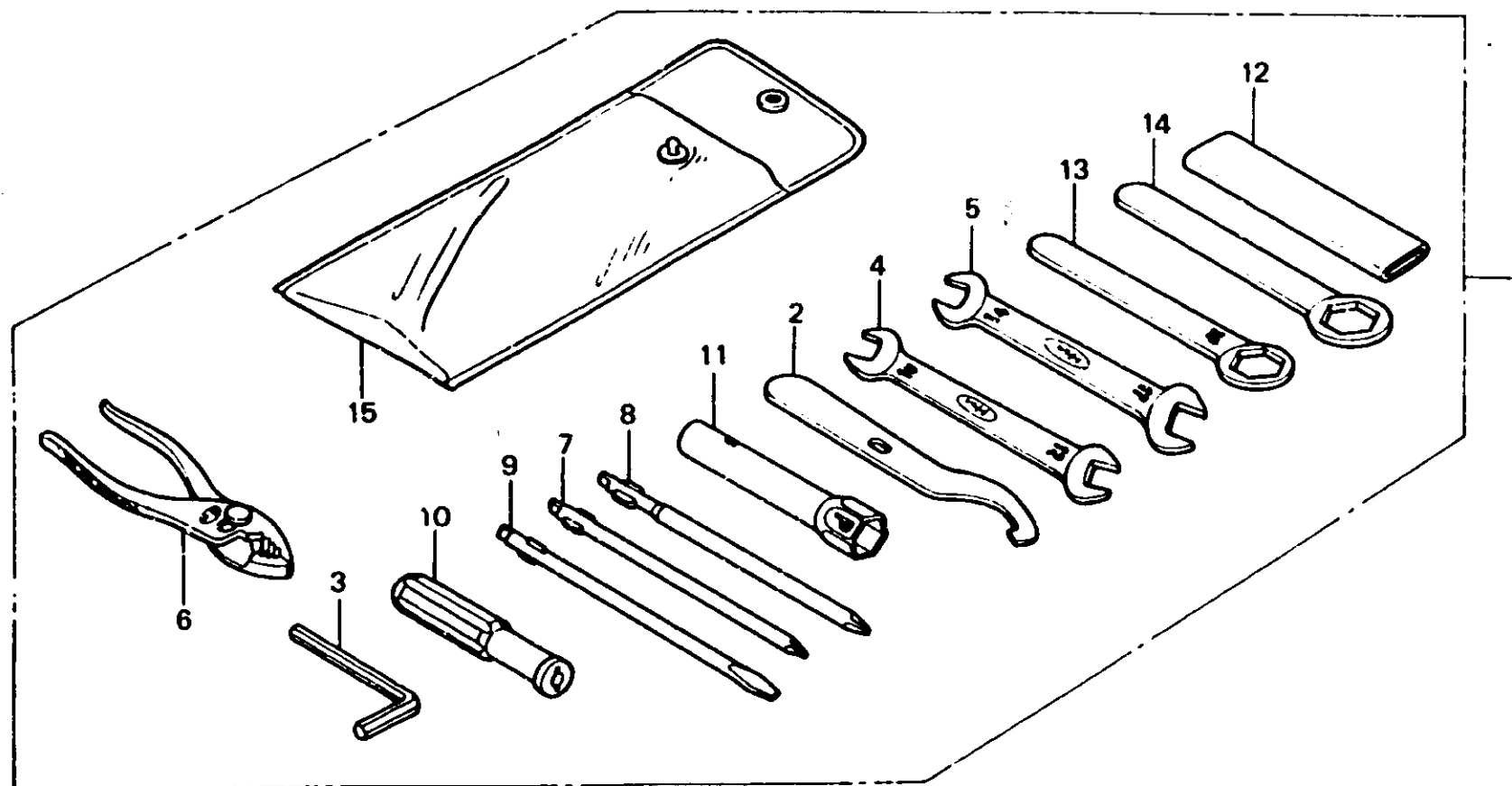

8413 488

Item d'entretien	T.D.R.	N° de réf.	N° de pièce	Description	N° de requia				N° de série	Code de zone
					250 NDC	400 Nc	250 NDo	400 No		
		1	89010-443-810	JEU D'OUTILS	1	1	1	1		
		2	89215-404-670	CLE COUDEE	1	1	1	1		
		3	89221-371-000	CLE HEX. 6MM	1	1	1	1		
		4	99001-10120	CLE, 10X12	1	1	1	1		
		5	99001-14170	CLE, 14X17	1	1	1	1		
		6	99002-13500	PINCES, 135	1	1	1	1		
		7	99003-10000	TOURNEVIS 2 DE (+)	1	1	1	1		
		8	99003-20000	TOURNEVIS 3 DE (+)	1	1	1	1		
		9	99003-30000	TOURNEVIS 2 DE (-)	1	1	1	1		
		10	99003-50000	POIGNEE	1	1	1	1		
		11	99004-18001	CLE A DOUILLE, P18	1	1	1	1		
		12	99006-12000	POIGNEE DE CLE A OEIL, 120MM	1	1	1	1		
		13	99006-19000	CLE A OEIL, 19MM	1	1	1	1		
		14	99006-22000	CLE A OEIL, 22MM	1	1	1	1		
		15	99008-02000	SAC D'OUTILS, 200MM	1	1	1	1		