



F-15

Right side cover • Battery

Couvercle latéral droit • Batterie

Rechter Seitendeckel • Batterie

Cubierta lateral derecha • Batería

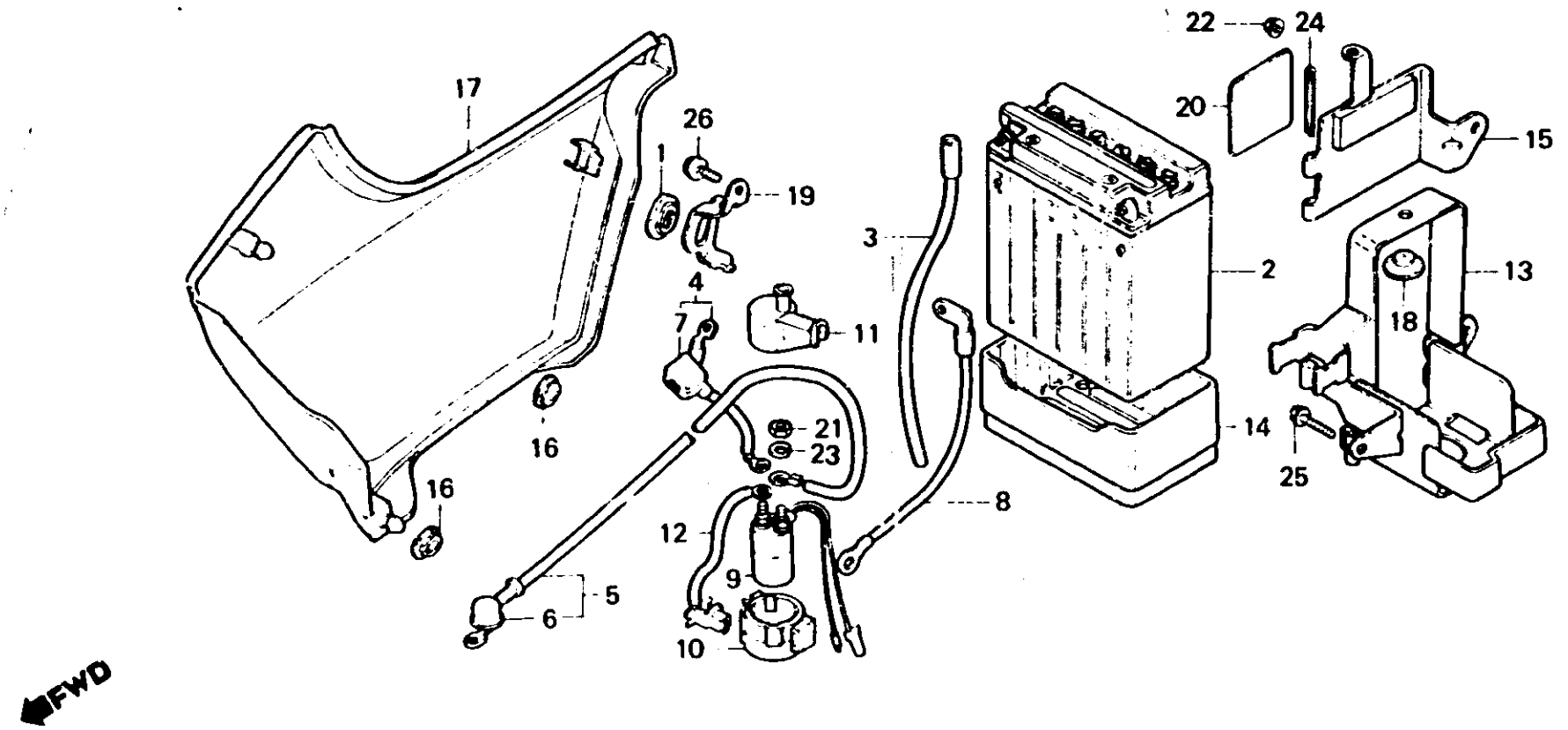

B443-95A

Item d'entretien	T.D.R.	N° de réf.	N° de pièce	Description	N° de requis				N° de série	Code de zone
					250 NDx	400 Nc	250 NDo	400 No		
		14	50326-413-781	AMORTISSEUR DE BATTERIE	1	1	1	1		
		15	50327-443-760	BANDE D'ATTACHE BATTERIE	1	1	1	1		
		16	83551-300-000	ANNEAU DE BOITIER DE FILTRE A AIR	2	2	2	2		
		17	836A0-442-930ZA	COUVERCLE COMP. LATERAL D. *R-107C-U*	1					
			836A0-442-930ZB	COUVERCLE COMP. LATERAL D. *NH-1*	1					
			836A0-442-930ZC	COUVERCLE COMP. LATERAL D. *NH-104M-U*	1					
			836A0-442-930ZD	COUVERCLE COMP. LATERAL D. *PB-107C-U*	1					
			836A0-443-930ZA	COUVERCLE COMP. LATERAL D. *R-107C-U*		1				
			836A0-443-930ZB	COUVERCLE COMP. LATERAL D. *NH-1*		1				
			836A0-443-930ZC	COUVERCLE COMP. LATERAL D. *NH-110M-U*		1				
			836A0-443-930ZD	COUVERCLE COMP. LATERAL D. *PB-115C-U*		1				