

# Coolant

3. Remove the radiator cap lid (4) by disengaging the stud (5) from the grommet (6).
4. Remove the reserve tank cap (7).  
Always add coolant to the reserve tank. Do not attempt to add coolant by removing the radiator cap.
5. Add coolant to the reserve tank as required to bring the coolant level to the UPPER level mark.

FRONT

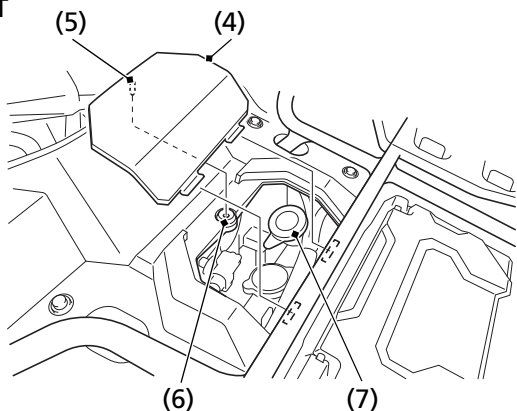

(4) radiator cap lid  
(5) stud

(6) grommet  
(7) reserve tank cap

6. After adding coolant, reinstall the reserve tank cap.
7. Install the radiator cap lid.