

Do not depress the brake lever when the wheel is off the motorcycle. The caliper piston will be forced out of the cylinder with subsequent loss of brake fluid. If this occurs, servicing of the brake system will be necessary. See your Honda dealer for this service.

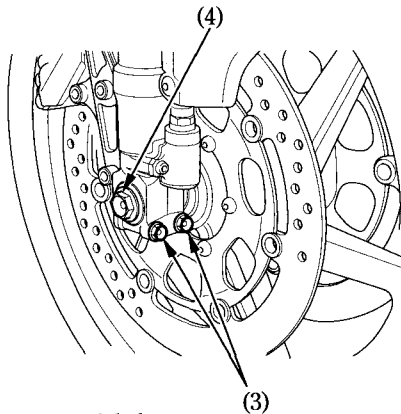

- (3) Axle pinch bolts
- (4) Axle bolt

3. Loosen the right and left axle pinch bolts (3), and remove the axle bolt (4).
4. Withdraw the front axle (5) and remove the front wheel.

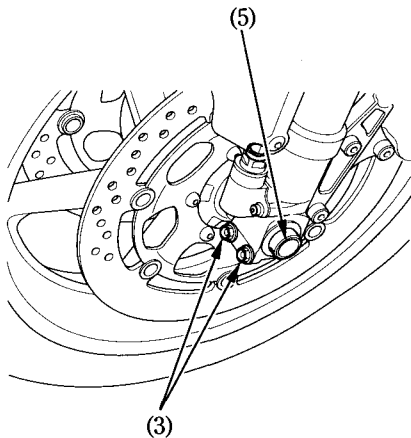

- (5) Front axle